

## pocl: A Performance-Portable OpenCL Implementation

**Pekka Jääskeläinen · Carlos Sánchez de La Lama ·  
Erik Schnetter · Kalle Raiskila · Jarmo Takala ·  
Heikki Berg**

Received: 7 February 2014 / Accepted: 5 August 2014 / Published online: 19 August 2014  
© Springer Science+Business Media New York 2014

**Abstract** OpenCL is a standard for parallel programming of heterogeneous systems. The benefits of a common programming standard are clear; multiple vendors can provide support for application descriptions written according to the standard, thus reducing the program porting effort. While the standard brings the obvious benefits of platform portability, the performance portability aspects are largely left to the programmer. The situation is made worse due to multiple proprietary vendor

---

P. Jääskeläinen (✉) · J. Takala  
Tampere University of Technology, Tampere, Finland  
e-mail: pekka.jaaskelainen@tut.fi

J. Takala  
e-mail: jarmo.takala@tut.fi

C. S. de La Lama  
Knowledge Development for POF, Madrid, Spain  
e-mail: carlos.sanchez@kdpof.com

E. Schnetter  
Perimeter Institute for Theoretical Physics, Waterloo, ON, Canada

E. Schnetter  
Department of Physics, University of Guelph, Guelph, ON, Canada

E. Schnetter  
Center for Computation and Technology, Louisiana State University, Baton Rouge, LA, USA  
e-mail: eschnetter@perimeterinstitute.ca

K. Raiskila · H. Berg  
Nokia Research Center, Espoo, Finland  
e-mail: kalle.raiskila@nokia.com

H. Berg  
e-mail: heikki.berg@nokia.com

implementations with different characteristics, and, thus, required optimization strategies. In this paper, we propose an OpenCL implementation that is both portable and performance portable. At its core is a kernel compiler that can be used to exploit the data parallelism of OpenCL programs on multiple platforms with different parallel hardware styles. The kernel compiler is modularized to perform target-independent parallel region formation separately from the target-specific parallel mapping of the regions to enable support for various styles of fine-grained parallel resources such as subword SIMD extensions, SIMD datapaths and static multi-issue. Unlike previous similar techniques that work on the source level, the parallel region formation retains the information of the data parallelism using the LLVM IR and its metadata infrastructure. This data can be exploited by the later generic compiler passes for efficient parallelization. The proposed open source implementation of OpenCL is also platform portable, enabling OpenCL on a wide range of architectures, both already commercialized and on those that are still under research. The paper describes how the portability of the implementation is achieved. We test the two aspects to portability by utilizing the kernel compiler and the OpenCL implementation to run OpenCL applications in various platforms with different style of parallel resources. The results show that most of the benchmarked applications when compiled using pocl were faster or close to as fast as the best proprietary OpenCL implementation for the platform at hand.

**Keywords** OpenCL · LLVM · GPGPU · VLIW · SIMD · Parallel programming · Heterogeneous platforms · Performance portability

## 1 Introduction

Widely adopted programming standards help the programmer by reducing the porting effort when moving the software to a new platform. *Open Computing Language (OpenCL)* [33] is a relatively new standard for parallel programming of heterogeneous systems. OpenCL allows the programmer to describe the program parallelism by expressing the computation in the *Single Program Multiple Data (SPMD)* style. In this style, multiple parallel *work-items* execute the same kernel function in parallel with synchronization expressed explicitly by the programmer. Another key concept in OpenCL is the *work-group* which collects a set of coupled *work-items* possibly synchronizing with each other. However, across multiple *work-groups* executing the same kernel there cannot be data dependencies. These concepts allow exploiting parallelism in multiple levels for a single kernel description; inside a work-item, across work-items in a single work-group and across all the work-groups in the *work-space*.

While the OpenCL standard provides an extensive programming platform for portable heterogeneous parallel programming, the version 1.2 of the standard is quite low-level, exposing a plenty of details of the platform to the programmer. Thus, using these platform queries, it is possible to adapt the program to each of the platforms. However, this means that to achieve performance portability, the programmer has to explicitly do the adaptation for each program separately. In addition, implementations of the OpenCL standard are vendor and platform specific, thus acquiring the full performance of an OpenCL application requires the programmer to become familiar with the special characteristics of the implementation at hand and tune the program

accordingly. This is a serious drawback for performance portability as manual optimizations are needed to port the same code to another platform.

In our earlier work [28], we used kernel serialization for extracting instruction-level parallelism for a statically scheduled processor template with the OpenCL vendor extension interface used for providing seamless access to special function units. This initial approach proved to be a good basis for a kernel compiler with improved support for performance portability. In this article, we propose kernel compilation techniques that expose the implicit parallelism of OpenCL multiple work-item (WI) work-groups in a form that can be exploited in different types of parallel processing hardware. We propose a set of compiler transformations, which together produce multi-WI work-group functions that can be parallelized in multiple ways and using different granularities of parallel resources, depending on the target. By separating the *parallel region* extraction from the actual parallel mapping of the multi-WI work-groups, we obtain a basis for improving the performance portability of OpenCL kernels. We have realized the proposed transformations as a modularized set of passes using the LLVM compiler infrastructure [35] and integrated them in an OpenCL implementation called *Portable Computing Language (pocl)*. We have used *pocl* to run applications on different processor architectures with different parallelism capabilities to test the applicability of the proposed approach.

The main contributions of this article are as follows:

- OpenCL kernel compilation techniques that separate the parallel region formation from multiple WI work-group functions from the actual platform specific parallelization methods;
- a kernel compiler that works on the LLVM IR, thus can support more kernel languages than OpenCL C via the Standard Portable Intermediate Representation (SPIR) standard [34]; and
- a complete OpenCL implementation, which allows performance portability over wide range of computing architectures with different styles and degrees of parallel hardware.

The remainder of the article is organized as follows. The first section is an overview to the OpenCL standard. It briefly describes its concepts that are relevant to understanding the rest of the article. The higher level software architecture of our OpenCL implementation, *pocl*, containing the proposed transformation passes is given in Sect. 3. The actual kernel compiler techniques are described in Sect. 4. Section 5 describes the vectorized mathematical functions used in *pocl*. Section 6 evaluates the applicability of the proposed approach on several platforms and compares the performance to the proprietary OpenCL implementations. Section 7 compares the proposed techniques to the related work. Finally, conclusions and the planned future work are presented in Sect. 8.

## 2 Open Computing Language

The *OpenCL 1.2 framework* specifies three main parts: The *OpenCL Platform Layer* for querying information of the platform and the supported devices, the *OpenCL Runtime* providing programming interfaces for controlling the devices by queuing

**Fig. 1** Vector dot product in OpenCL C

```
kernel void
dot_product (global const float4 *a,
             global const float4 *b,
             global float *c)
{
    int gid = get_global_id(0);

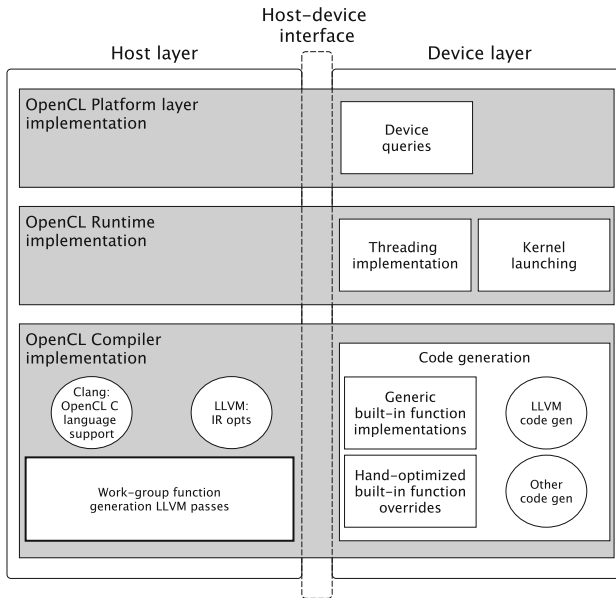
    c[gid] = dot(a[gid], b[gid]);
}
```

them kernel execution and memory transfer commands, and the *OpenCL Compiler* for compiling the OpenCL C kernels for each targeted device. OpenCL programs structure the computational parts of the application into *kernels* defined in the OpenCL C kernel language, and specify that there shall be no data dependencies between the “kernel instances” (*work-items*, analogous to loop iterations) by default.

The example OpenCL C kernel in Fig. 1 can be executed on different width *Single Instruction Multiple Data (SIMD)* hardware in parallel, parallelizing as many *work-items* as there are parallel processing elements in the device. The call to *get\_global\_id(0)* returns the index of the work-item in the *global index space* which in this case maps directly to the index in the buffers. A difference to standard C notation in this example is the use of the *global* qualifier in the kernel arguments. This is used to mark the pointers to point to buffers in *global memory*. Other disjoint explicitly addressed memory spaces in OpenCL C include the *local memory* visible to single *work-groups* (groups of work-items within the global index space that can synchronize with each other) at a time, the *private memory* visible only to single *work-items*, and the *constant memory* for storing read-only data. The kernel can use vector datatypes, e.g. *float4* is a four element floating point vector.

The OpenCL runtime API (a C language API) is used to launch kernels and data transfer commands in one or more *compute devices* with *event* synchronization. Thus, the targeted OpenCL platform consists of a host device that executes the top level program and one or more devices that perform the computation. Portability of OpenCL programs across a wide range of different heterogeneous platforms is achieved by describing the kernels as source code strings which are then explicitly compiled using the runtime API to the targeted devices. Thus, even if the runtime part of the application was distributed as a platform specific binary, the device programs can be recompiled to each device using the OpenCL C compiler of the platform at hand. In the kernel execution, the OpenCL programmer can describe two forms of parallelism: work-item parallelism and work-group level parallelism. Parallelism within a single work-item can be explicitly expressed using vector computations. In addition, the implicit instruction level parallelism that can be described in traditional C functions is also available: the programmer can define, e.g., for-loops inside work-items that can be parallelized by the compiler or the hardware, if there are no dependencies restricting the parallelization.

The important additional source of parallelism is the data level parallelism described by multi-WI work-groups. In OpenCL 1.2, multiple work-items in a work-group that execute an instance of the same kernel described in the OpenCL C programming language can be assumed to be independent by default with only explicit synchronization



**Fig. 2** The subcomponents in the OpenCL implementation. The host layer includes parts that are executed in the OpenCL host. The device layer is used as a hardware abstraction layer to encapsulate the device-specific parts

constructs limiting the parallelism [33]. Thus, the device is free to execute the work-items in parallel or in serial manner. Task and thread level parallelism can be also exploited in OpenCL applications. Multiple work-groups are assumed to be independent of each other, thus can be executed in parallel to exploit multiple hardware threads or multiple completely independent cores. In addition, at the higher level of OpenCL applications, separate commands in an out-of-order command queue, and commands in different command queues can be assumed to be independent of each other unless explicitly synchronized using events or command-queue barriers.

### 3 Portable OpenCL Implementation

The proposed kernel compilation techniques are included in our OpenCL implementation, *pocl*. We give an overview of its software architecture before going to the details of the transformations. The software architecture of *pocl* is modularized to encourage code reuse and to isolate the device specific aspects of OpenCL to provide a platform portable implementation. The higher-level components of *pocl* are illustrated in Fig. 2. The implementation is divided to parts that are executed in the host and to those that implement device-specific behavior. The *host layer* implementation is portable to targets with operating system C compiler support. The *device layer* encapsulates the operating system and *instruction-set architecture (ISA)* specific parts such as code generation for the target device, and orchestration of the execution of the kernels in the device.

Most of the API implementations of the OpenCL framework in *pocl* are generic implementations written in C which call the *device layer* through a generic *host–device interface* for device-specific parts. For example, when the OpenCL program queries for the number of devices, *pocl* returns a list of supported devices without needing to do anything device-specific yet. However, when the application asks for the size of the global memory in a device, the query is delegated down to the device layer implementation of the device at hand.

The device layer consists of target-specific implementations for functionality such as target-specific parts of the kernel compilation process, the final execution of the command queue including uploading the kernel to the device and launching it, querying device characteristics, etc. The responsibilities between the device-specific and generic parts in the currently supported device interfaces are as follows:

- `basic` A minimal example CPU device implementation. The execution of kernels happens one work-group at a time without multithreading. This driver can be used for implementing a device on a POSIX-compliant operating system for the case where the host and the device are the same.
- `pthread` Similar to 'basic' except that it uses the POSIX threads [25] library to execute multiple work-groups in parallel. This is an example of a device layer implementation that is capable of exploiting the thread level parallelism in multi-work-group execution.
- `ttasim` A proof-of-concept implementation of a simulated heterogeneous accelerator setup. The driver simulates customizable *Transport-Triggered Architecture (TTA)* [15] based accelerators executing the kernels. The processors are simulated by calling the instruction set simulator of the *TTA-based Co-design Environment (TCE)* [17]. The driver performs the memory management of the device memories at the host side, and controls the kernel execution at the device.
- `cellspu` Another (experimental) heterogeneous accelerator device. This controls a single *Synergistic Processing Elements (SPE)* in the heterogeneous Cell [20] architecture running a Linux-based operating system. It uses the *libspe* for interfacing with the SPE.

It should be noted that each of the previous device layers provide varying levels of portability themselves. For example, the *pthread* device layer implementation can be used with *Symmetric Multi-Processing (SMP)* systems that run an operating system which supports the pthreads API, regardless of the underlying CPU architecture. The *ttasim* driver, on the other hand, assumes a specific communication mechanism through explicit messages and buffer transfers using DMA commands.

One important responsibility of a device layer implementation is resource management, that is, ensuring the resources of the device needed for kernel execution resources are properly shared and synchronized between multiple kernel executions. The allocation of the OpenCL buffers from the device memory requested via the *clCreateBuffer* and similar APIs is also part of the resource management responsibility of the device layer.

For assisting in memory management, *pocl* provides a memory allocator implementation called *Bufalloc* which aims to optimize the allocation of large continuous buffers

typical in OpenCL applications. There are two main motivations for the customized kernel buffer allocator: (1) exploit the knowledge of the “throughput computing” workloads of OpenCL where the buffers are usually relatively big to reduce fragmentation, and (2) offer a generic memory allocator for devices without such support on device.

The working principle of the allocator is similar to *memory pools* in that a larger region of memory can be allocated at once with a single *malloc* call (or at compile time by allocating a static array). Chunks of this region are then returned to the application using a fast allocation strategy tailored for the OpenCL buffer allocation requests. As the allocation of the initial region can be done in multiple ways, the same memory allocator can be also used to manage memory for devices without operating systems. In that case, the host only keeps book of all the buffer allocations using Bufalloc for a known available region in the device memory and the device assumes all the kernel buffer pointers are initialized by the host to valid memory locations. The memory allocation strategy is designed according to the assumption that the buffers are long lived (often for the whole lifetime of the OpenCL application) and are allocated and deallocated in groups (space for all the kernel buffer arguments reserved and freed with successive calls to the allocator). These assumptions imply that memory fragmentation can be reduced by allocating neighboring areas of the memory for the successive allocation requests. A simple first fit algorithm is used in finding free space for the buffer allocation requests.

The internal book keeping structure of Bufalloc is split to *chunks* with a free/allocated flag and a size. The chunks are ordered by their starting address in a linked list. The last chunk in the list is a sentinel that holds all the unallocated memory. When a buffer allocation request is received, the linked list is traversed from the beginning to the end until an unallocated chunk with enough space is found. This chunk is then split to two chunks; one having the exact size of the buffer request that is returned to the caller, and another carrying the rest of the unallocated space in the original chunk. The allocation strategy has a customizable *greedy* mode which always serves new requests from the last chunk (end of the region) if possible. This mode results more often in the successive kernel buffer allocation calls being allocated from continuous memory space given the original allocated region is large enough.

## 4 Performance Portable Kernel Compiler

The performance portability in our approach is obtained with an OpenCL kernel compiler which exposes the parallelism in the kernels in such a way that it can be mapped to the diverse parallel resources available in the different types of computing devices. In this section, we discuss the kernel compiler and provide details of the work-group function generation.

### 4.1 Compilation Chain Overview

The *pocl* kernel compiler is based on unmodified Clang [1] and LLVM [5] tools. Clang parses the OpenCL C kernels and produces an LLVM *Intermediate Representation (IR)* for the *pocl* kernel compiler passes. The generated LLVM IR contains the

representation of the kernel code for a single work-item, matching the original OpenCL C kernel description as an LLVM IR function.

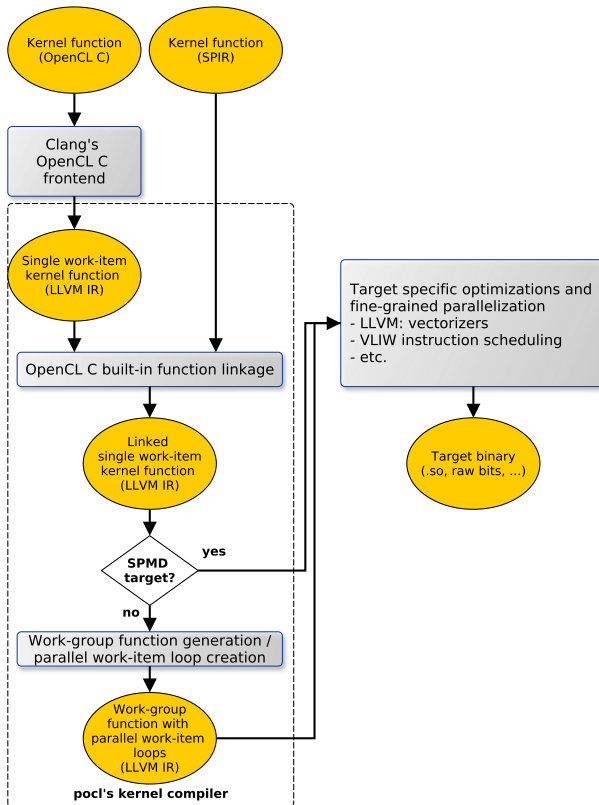
The kernel description can be thought of as a description of a thread which executes independently by default, and which is synchronized explicitly across other work-items in the same work-group by the programmer-defined barriers. The thread is then spawned as many times as there are work-items in the work-group, in the *Single Program Multiple Data (SPMD)* parallel program style.

Whether this single work-item program description can be executed directly on the device depends on the execution model of the target. If the target device is tailored to the SPMD style of parallelism it might be able to input a single kernel description and apply the same instructions over multiple data automatically. This is the case with many of the GPUs which implement an execution model called *Single Instruction Multiple Threads (SIMT)*. SIMT devices make it the responsibility of the hardware to spread the execution of the kernel description to multiple work-items that consist the work-group. Each SIMT core contains an independent program counter, but share the same instruction feed, so that the same kernel instruction is broadcast to all the cores with the same program counter value. Thus, the cores wait for their own separate part of the kernel in case of diverging execution, and continue with parallel execution whenever the work-items converge [41].

For *Multiple Instructions Multiple Data (MIMD)* or architectures with *Single Instruction Multiple Data (SIMD)* instructions, on the other hand, the semantics of a multi-WI work-group execution must be created by the compiler or the threading runtime. A straightforward implementation of OpenCL kernel execution on a MIMD device would simply spawn as many threads as there are work-items for the kernel function, and implement the work-group barriers using barrier synchronization primitives. However, as OpenCL is optimized for high throughput massively parallel computation, this type of thread level parallelism is usually too heavy for work-item execution. Creating, executing, barrier-synchronizing and context switching hundreds or thousands of threads for each kernel invocation would incur so large overheads that the performance benefits of parallel work-item execution are easily ruined for at least the smaller kernel functions.

Moreover, in order to improve the performance portability of the OpenCL programs, it is desirable to map the work-items in a work-group over all the parallel resources available on the device at hand. For example, if the target supports SIMD instructions as instruction set extensions, the compiler should attempt to pack multiple work-items in the work-group to the same vector instructions, one work-item per vector lane. In case of in-order superscalar or *Very Long Instruction Word (VLIW)* style *Instruction-Level Parallel (ILP)* architectures it might be beneficial to “unroll” the parallel regions in the kernel code in such a way that the operations of several independent work-items can be statically scheduled to the multiple function units of the target device. On the other hand, if vectorization across the work-group is not feasible, for example, due to excessive diverging control flow in the kernel, the most efficient way to produce the work-group execution might be to execute all the work-items serially using simple loops and rely on the work-item vector datatypes for vector hardware utilization. This alternative minimizes the instruction cache footprint and might still be able to exploit instruction parallel execution of multiple work-items in case of out-of-order hardware.





**Fig. 3** A high level illustration of pocl's kernel compilation chain. The source code of the kernel is read by Clang which produces an LLVM IR for the single work-item kernel description. Alternatively, a pre-built SPIR bitcode binary can be used as an input. The OpenCL C built-in functions are linked at the LLVM IR level to the kernel after which the optional work-group function generation is done. In case the target can execute the SPMD single work-item kernel description directly for all work-items in the work-group (as is the case with most GPUs), or the local size is one, this step is skipped. The work-group function generation is the last responsibility of the pocl's kernel compiler; it helps the later target-specific passes (such as vectorization) by creating parallel work-item loops which are annotated using LLVM metadata

An overview of the kernel compilation process of pocl is depicted in Fig. 3. First, the OpenCL kernel (if given in source form) is fed to the Clang OpenCL C frontend which produces an LLVM IR of the kernel function for a single work-item. SPIR is an alternative input format which allows to skip the Clang phase.

The LLVM IR function that describes the behavior of a single work-item in the work-group is then processed by the pocl's kernel compiler, which links the IR against an LLVM IR library of device-specific OpenCL built-in function implementations at the bitcode level. The function is converted to a *work-group function* (in case of a non-SPMD execution model target) that generates a version of the function that statically executes all the work-items of the work-group. This is done using the work-group function generation passes of pocl.

When compiling to SPMD-optimized hardware such as SIMT GPUs,<sup>1</sup> the generation of the work-group function is not necessary as the hardware produces the multiple parallel work-item execution. However, it is sometimes still beneficial to merge multiple work-items to expose instruction-level parallelism in case the cores contain multiple function units.

The work-group function is a version of the original kernel with data parallel regions across the independent work-items exposed to the later phases of the compiler. It consists of parallel “work-item loops” that execute so called “parallel regions” for all work-items. The parallel regions are formed according to the barriers in the kernel.

Currently the work-group function generation is performed at *kernel enqueue* time, when the local size is known. The known local size makes it possible to set constant trip counts to the work-item loops, leading to easier static parallelization later on in the compilation chain. For example, a vectorizer can then easily see whether the trip counts can be covered evenly with the maximum size vector instructions in the machine. Otherwise, it would always need to create a copy of the loop that iterates the “overhead iterations” that could not be covered evenly with the vector instructions. The drawback of this approach is that one work-group function needs to be generated for each local size. If the same kernel is executed with a lot of different local sizes, it leads to compilation time increase. We have not seen this as a problem yet in our test cases. However, it would be trivial to add a version of the work-group function with variable trip counts in the work-item loops to produce a work-group function that can be used with all local sizes, but might not be so efficiently parallelizable.

The produced work-group function is in a format that can be launched for different parts of the work-space in parallel. This can be seen as an additional struct function argument added to the work-group function that contains the work-space coordinates among other information. In addition, the automatic local array visible in the original kernel source is converted to a function argument to unify the handling of local buffers which can be allocated both by the host and by the kernel.

Finally, the work-group function is passed to the code generator and assembler which generate the executable kernel binary for the target device. The work-group function is potentially accompanied with a launcher function in case of a heterogeneous device. In that case the device contains its own main function which executes the work-group function on-demand.

## 4.2 Generation of Parallel Work-Group Functions

The main responsibility of the kernel compiler of pocl is generating a new work-group function out of the single work-item kernel function that is produced by the Clang frontend. The work-group function executes the kernel code for all the work-items in a work-group of a given size and exposes the parallel parts between work-items in a way that can be potentially exploited by a target specific vectorization pass or an

---

<sup>1</sup> At the time of this writing, pocl does not yet support popular commercial GPU targets. However, the SPMD/GPU path of the kernel compiler has been tested by using research targets to ensure GPU-like devices can be supported using pocl.

instruction scheduler/bundler. In practice, the parallel loops are annotated with LLVM metadata that retains the information of the parallel iterations for later phases such as the loop vectorizer, which then does not have to prove the independence of the loop iterations to perform vectorization.

Producing multi-WI work-group functions is not trivial due to the need to respect the synchronization semantics of the work-group barriers inside the kernel code. That is, the multiple work-item execution cannot be implemented by simply adding a loop around the kernel code that executes the function for all the work-items, but the regions between the barriers must be parallelized separately. Statically parallelizing kernels with barriers inside conditional regions such as for-loops or if-else-structures adds further complexity. In such cases the regions between barriers are harder to parallelize due to the varying paths the execution can take to the barrier call. The pocl kernel compiler is modularized to parts that are reusable across several parallelization methods. For example, all of the methods for implementing static parallel computation on the device need to identify the *parallel regions* in the kernels (regions between barriers) which can be then mapped to the parallel resources in multiple ways.

Throughout the following algorithm descriptions the kernels are represented as *Single Static Assignment (SSA)* [16] *Control Flow Graphs (CFG)* [9] of the LLVM IR. The relevant characteristics of the internal representation are as follows:

- Variable assignments and operations are abstracted as *instructions*. Instructions have at most one result, and referring to an instruction means referring also to its output value if it exists.
- A node in a CFG is a *Basic Block (BB)*. A BB is a branchless sequence of *instructions* which is always executed as an entity, from the first instruction to the last.
- An edge in a CFG represents a branch in the control flow. These edges are defined by the jump instructions in the *source* BB. This implies that creating a copy  $B'$  of a basic block  $B$  which has an edge to basic block  $C$  results in  $B'$  also having an edge to  $C$ .
- Both the source and the destination BBs of any CFG edge belong to the CFG. This is important characteristics in order to differentiate between a CFG and a sub-CFGs, defined below.
- Multiple *exit BBs* are allowed. Typically the exit BBs are blocks that return from the function at hand.

We also define the term *sub-CFG*, to refer to a CFG which is a subgraph of another CFG. A sub-CFG always has an associated CFG, and has essentially the same properties as CFGs, save that it might have edges leading to blocks that do not belong to the sub-CFG but to the parent CFG.

There are two helper functions which are used in the algorithm descriptions later in this section. Function *CreateSubgraph* finds all the nodes which can potentially be visited when traversing from node  $A$  to node  $B$ . This function can be used to construct a single-entry single-exit subgraph between two given nodes. It can be implemented with a depth-first search starting from the desired subgraph entry  $A$  and keeping record of all the nodes visited when traversing all the possible paths to the subgraph exit node  $B$  and by ignoring edges back to an already visited node to avoid infinite loops.

Function *ReplicateCFG* takes a CFG or a sub-CFG and replicates the whole graph. Thus, it copies both the BBs in the and their edges creating an identical copy of the graph as a whole.

### 4.3 Parallel Region Formation

The generation of static multi-WI work-group functions involves identifying the regions between barriers that must be executed by all the work-items before proceeding to the next region. These regions are referred to as *parallel regions* or simply *regions* in the rest of this article.

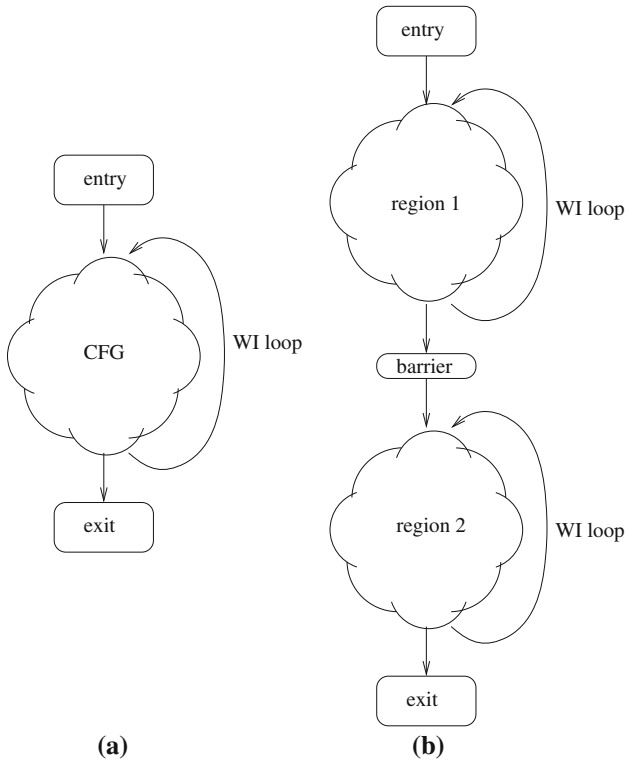
The work-items in the work-group can execute the code in the parallel regions in any order relative to each other due to the the relaxed consistency model of the device memory in the OpenCL 1.2 standard [33]. Thus, the multi-WI functions can be implemented as “embarrassingly parallel” loops that iterate over all the work-item local ids with a parallel region as the loop body. The parallel loops (later referred to as *WI loops* as in work-item loops) often form the main source of fine-grained parallelism available for the parallel computation resources in the targeted device.

The simplest scenario for forming the parallel regions is a kernel without barriers. In such a case, creating a work-item loop whose body is the CFG of the whole function is sufficient (see Fig. 4a). Thus, a single parallel region consisting the whole kernel function is formed. The only requirement for this to work is that the original CFG has a single entry point; (this is always true for the kernel functions as the function can be entered only from one location), and a single exit point. The latter can be achieved by a normalization transformation on the kernel function.

The parallel region formation for kernels with barriers is more complex. In the following, the work-group barriers are classified to two categories. If a barrier is reached in all the execution paths of the kernel control flow, that is, if the barrier *dominates* the exit node, we call it an *unconditional barrier*. In case the barrier is placed inside a conditional BB such as an if...else structure or a for-loop (the barrier does *not dominate* the exit node), we call it a *conditional barrier*. Unconditional barriers create separate *parallel regions*, sections of the CFG which the different work-items can execute in parallel. In Fig. 4b, the unconditional barrier divides the whole CFG into two regions. In order to comply with the barrier semantics, no work-item should execute the *region 2* until all of them have finished executing the *region 1*. Thus, two WI loops must be created, one iterating over each parallel region; one before, and one after the barrier. The parallel region formation algorithm for kernels with only unconditional barriers is given in Algorithm 1.

### 4.4 Handling of Conditional Barriers

The algorithm for parallel region formation described so far can only handle kernels which either have no barrier synchronization at all, or have only unconditional barriers. According to OpenCL specification, “the work-group barrier must be encountered by all work-items of a work-group executing the kernel or by none at all” [33]. In order to describe the way how *pocl* handles kernels with conditional barriers, a few new definitions are needed.



**Fig. 4** Two basic cases of static work-group function generation: A kernel **a** without work-group barriers and **b** with an unconditional barrier in the middle

---

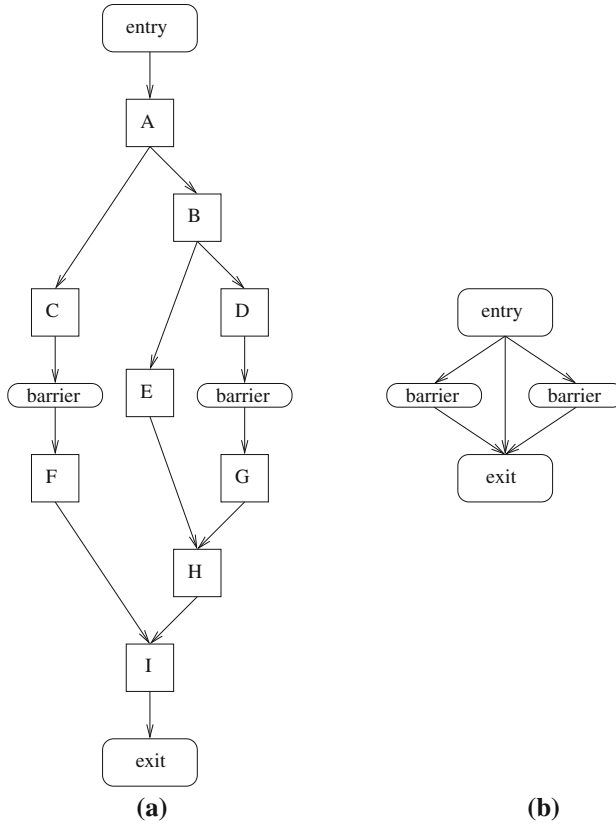
**Algorithm 1:** Parallel region formation when the kernel does not contain conditional barriers.

---

1. Ensure there is an implicit barrier at the entry and the exit nodes of the kernel function and that there is only one exit node in the kernel function. This is a safe starting condition as it does not affect any execution order restrictions.
  2. Perform a depth-first-search traversal of the kernel CFG. Ignore the possible back edges to avoid infinite loops and to include the loops of the kernel to the parallel region.
  3. When encountering a barrier, create a parallel region by calling *CreateSubgraph* for the previously encountered barrier and the newly found barrier.
- 

**Definition 1** (*Barrier CFG*) A reduced CFG with all the non-barrier instructions and basic blocks eliminated. An example barrier CFG is shown in Fig. 5b. The barrier CFG is formed by producing a graph with only the barrier, exit and entry nodes of the original CFG. There is an edge between two nodes if and only if there is a direct (no-barrier) path between the two nodes in the original CFG. Exit and entry nodes contain implicit barriers.

**Definition 2** (*Predecessor barrier*) Given a barrier  $b$ , its predecessor barriers are all the barriers which can be visited in a path leading to  $b$  from the entry node. They



**Fig. 5** **a** An example CFG with two conditional barriers and **b** its reduced barrier CFG

correspond to predecessor nodes in the reduced Barrier CFG. Every barrier except the implicit barrier at the entry node has at least one predecessor barrier.

**Definition 3** (*Successor barrier*) Given a barrier  $b$ , its successor barriers are all the barriers that might be reached on any path from  $b$  to the exit node. They correspond to successor nodes in the reduced Barrier CFG. Every barrier except the implicit barrier at the exit node has at least one successor barrier.

**Definition 4** (*Immediate predecessor barrier*) A barrier node preceding a given barrier node in the Barrier CFG.

**Definition 5** (*Immediate successor barrier*) A barrier node succeeding a given barrier node in the Barrier CFG.

Assuming there is at least one exit node in the kernel function, we can state that:

**Proposition 1** *If there is a conditional barrier in a kernel CFG, then there is at least one other barrier which has more than one immediate predecessor barrier.*

*Proof* Let  $U = \{u_i\}$  be the set of all the unconditional barriers in the Barrier CFG and  $C = \{c_j\}$  the non-empty set of all the conditional barriers. The implicit barrier on the exit node has to be in  $U$  (exit node is not conditional), thus there is at least one edge  $e$  from a node  $c_j \in C$  to a node  $u_i \in U$ , otherwise there would be no path from any conditional barrier to the exit node. This would make all the nodes in  $C$  dead or unreachable basic blocks because if a node in  $C$  is executed at least by one work-item, all work-items must execute it after which the control shall proceed. Otherwise, as there is only one exit node in the kernel CFG, there must be an infinite loop after the conditional barrier and the kernel outcome is undefined. Moreover,  $e$  can not be the only edge leading to  $u_i$ , as then  $c_j$  would dominate  $u_i$ , which could only happen if both  $c_j$  and  $u_i$  were of the same kind (conditional or unconditional). Hence, there are at least two different edges leading to  $u_i$  in the Barrier CFG, thus  $u_i$  has at least two immediate predecessor barriers.

A barrier with two predecessor barriers makes it impossible to apply Algorithm 1 for forming the parallel regions. According to the simple algorithm, upon reaching a conditional barrier, a parallel region should be formed between the preceding barrier and the previously reached one, but in this case there would be ambiguity on which one is the preceding barrier. For example, in Fig. 5a, when reaching the exit node, the work-item loop iterating over the parallel region might have to branch back to either A, F, or G, depending on the execution path chosen by the first work-item (which the other work-items must follow, according to the OpenCL work-group barrier semantics).

In order to form a single entry, single exit parallel regions in the presence of conditional barriers, we apply a variant of *tail duplication* [37] to the set of basic blocks reachable from the conditional barrier at hand. This produces a new CFG with the same behavior as the original CFG, but in which each barrier can have only one immediate predecessor barrier, enabling the single entry single exit parallel region formation similarly as with unconditional barriers. The used tail duplication process is described in Algorithm 2.

---

**Algorithm 2:** Tail duplication for parallel region formation in the case of conditional barriers in the kernel.

---

1. Perform a depth-first traversal of the CFG, starting at the entry node.
  2. Each time a new, unprocessed conditional barrier is found, use *CreateSubgraph* to produce a sub-CFG from that barrier to the next exit node (duplicate the tail).
  3. Replicate the created sub-CFG using *ReplicateCFG*.  
 In order to reduce code duplication, merge the tails from the same unconditional barrier paths.  
 That is, replicate the basic blocks only after the last barrier that is unconditionally reachable from the one at hand.
  4. Start the algorithm again at each of the found barrier successors.
- 

The result of applying tail replication to the example CFG in Fig. 5 is shown in Fig. 6a. From its reduced barrier CFG (Fig. 6b) it can be seen that no barrier has more than one immediate predecessor barrier after this transformation has been performed, thus making the parallel region formation unambiguous.

It should be noted that the resulting tail replicated graph has irreducible loops [23]; multiple work-item loops share the same basic blocks which leads to branches from

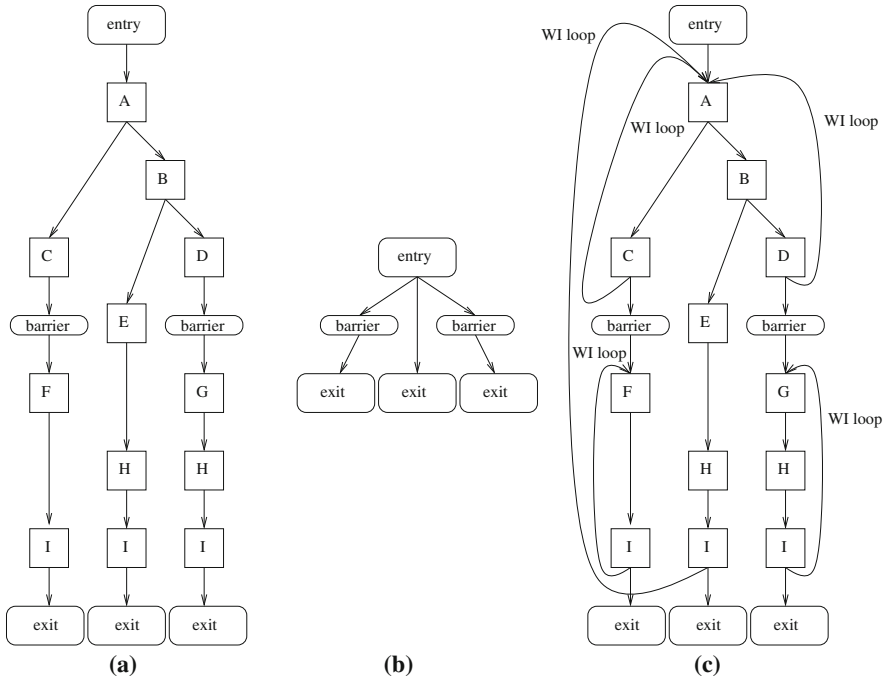


Fig. 6 a Example CFG after tail replication, b its reduced barrier CFG, and c parallelized version

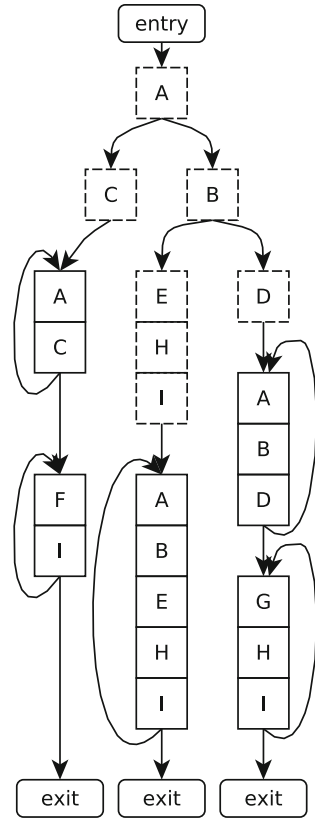
a work-item loop to another. For example, the basic blocks *A*, *B* and *D* form a parallel region and from *B*, there’s a branch to the middle of another parallel region’s (*ABEHI*) work-item loop. Removing branches from a work-item loop to another can be done by leaning on the definition of the OpenCL C work-group barriers: if at least one work-item takes the branch after *B* that can lead to a barrier, the rest of the work-items must follow. This fact can be exploited by “loop peeling” the first iteration of the work-item loop. This iteration is then the only one that evaluates the work-item dependent condition that chooses which parallel region should be executed by the rest of the work-items. Figure 7 depicts the CFG after loop peeling has been applied to the conditional barrier parallel regions. The peeled basic blocks are marked with dashed outline boxes. The peeled paths select the parallel region work-item loop that is then executed with the branch selecting the conditional barrier removed. The benefit for parallelization is apparent; for static multi-issue ILP targets the work-item loops contain now longer branchless traces from which to issue instructions to the parallel function units. In general, longer branchless traces produce more freedom to the compiler instruction scheduler which helps to hide latencies.

#### 4.5 Barriers in Kernel Loops

OpenCL allows kernel loops to have barrier synchronization inside loops. The semantics of a loop with a barrier (later referred to as *b-loops*) is similar to the conditional barriers: if one work-item reaches the barrier, the rest of them have to. The barrier

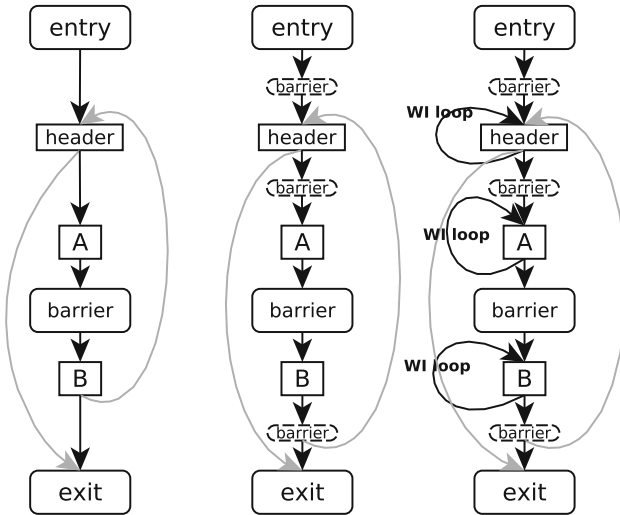


**Fig. 7** The kernel CFG after loop peeling applied to remove irreducible control flow from the work-item loops. The “peeled” basic blocks are marked with *dashed boxes*. This CFG does not contain the explicit barrier markers as the work-item loops itself implement the work-group barrier semantics



call at each kernel loop iteration is considered to be a separate barrier instance, that is, the barrier of each iteration must be reached by all the work-items before proceeding to the next iteration. The parallel region formation for b-loops can be reduced to the “regular” parallel region formation case by adding certain implicit barriers to the loop construct. The implicit barriers are added using the following assumptions:

1. All OpenCL kernel loops can be converted to natural canonical loops which have a single entry node, the loop *header*, that computes the loop condition and just one loop *latch* which jump back to the loop header. This can be assumed because the OpenCL standard declares kernels with irreducible control flow implementation-defined [33] and it is possible to convert irreducible loops (e.g. those produced by an earlier optimization) to reducible loops, e.g., via node splitting [29]. Additional transformations (included in LLVM passes) can canonicalize loops, ensuring that they have exactly one back edge.
2. All work-items execute the iterations of b-loops in lock-step, one parallel region at a time. Thus, the loop iteration count is the same for all work-items executing the b-loop.
3. If the b-loop has early exits, they have been converted to converge to a single loop exit basic block.



**Fig. 8** Adding implicit barriers to kernels with b-loops to produce unambiguous parallel regions; **a** the original single work-item kernel CFG with the b-loop, **b** the kernel CFG with implicit barriers added to make parallel region formation unambiguous, and **c** the work-group function CFG with the work-item loops added to iterate the parallel regions. The original kernel loop edges are colored grey

With the above assumptions, the following implicit barriers can be added in order to ensure unambiguous parallel region formation for b-loops:

1. End of the loop pre-header block. This is the single block preceding the loop header. That is, synchronize the work-items just before entering the b-loop.
2. Before the loop latch branch. The original loop latch branch is retained, thus a parallel region must be formed before it and the original loop branch preserved.
3. After the *PhiNode* region of the loop header block. This creates a parallel region for updating the induction variables and other loop-carried variables in the original kernel.

Due to the b-loop iteration-level lock step semantics, the induction variable updates are redundant for all the work-items and can be combined by the standard *common subexpression elimination* [14] optimization implemented by the LLVM. Depending on the target, however, the induction variables of the work-items might not be beneficial to be combined to a single variable, but duplicated, to avoid the need to broadcast the single induction variable across all the vector lanes.

Figure 8 shows how the implicit barriers direct the parallel region formation in a kernel with a b-loop. The explicit (programmer-defined) barrier is shown with a solid outline box, and the implicit barriers added by the compiler are highlighted with dashed boxes. It should be emphasized that the original b-loop branches in the single work-item kernel (the gray edges in Fig. 8) are not replicated during the work-group function generation. This enforces the semantics of the iteration level lock step execution of b-loops: When a single work-item stops iterating the loop or begin a new iteration, so shall the others.

```

__kernel
void DCT(__global float * output,
        __global float * input,
        __global float * dct8x8,
        __local float * inter,
        const uint width,
        const uint blockWidth,
        const uint inverse)
{
    /* ... */
    /* parallel_WI_loop { */
        for(uint k=0; k < blockWidth; k++)
        {
            uint index1 = (inverse)? i*blockWidth + k : k * blockWidth + i;
            uint index2 = getIdx(groupIdx, groupIdy, j, k, blockWidth, width);

            acc += dct8x8[index1] * input[index2];
        }
        inter[j*blockWidth + i] = acc;
    /* } */
    barrier(CLK_LOCAL_MEM_FENCE);
    /* ... */
}

```

**Fig. 9** A kernel with inner loops; a snippet from the DCT kernel of the AMD OpenCL SDK code sample suite. Note how the work-item loop surrounds the inner-loop which constitutes a parallel region

#### 4.6 Horizontal Inner-Loop Parallelization

The loop constructs in OpenCL C kernel descriptions, written by the programmer, are like C loops with sequential execution semantics. Therefore, in order to parallelize the loops the same loop carried dependency analysis as in sequential programs is needed. In case of multi-WI work-groups, these “inner loops” can be sometimes parallelized “horizontally” across work-items in the work group, thus leading to a more easily parallelized program (the work-item loop is a parallel loop). In other words, the loop iterations could be executed in lock step for each work-item before progressing to the next iteration. For example, the imaginary kernel in Fig. 9 does not parallelize well without extra treatment.

The variable loop iteration count makes parallelism extraction hard as the inner loop cannot be unrolled to increase the number of parallel operations within one work-item. However, if the inner loop was treated like a loop with a barrier inside, the parallelization would be done across the work-items, effectively leading to a structure as shown in Fig. 10. Thus, the desired end result is a loop interchange between the inner loop and the work-item loop surrounding that parallel region.

The legality of this transformation is similar to the legality of having a barrier inside the loop; all of the work-items have to iterate the loop the same amount of times. Therefore, additional *divergence and variable uniformity analysis* is needed in order to add such implicit barriers that enforce the horizontal parallelization.

The uniformity analysis resolves the origin of the variables in the LLVM IR. The operands of the producer instruction of the variable are recursively analyzed until a known *uniform* root is found. Uniform variable is one that is known to contain the same value for all the work-items in the work-group. Such a uniform root is usually a

```

for(uint k=0; k < blockDim; k++)
{
  /* parallel_WI_loop { */
  uint index1 = (inverse)? i*blockWidth + k : k * blockDim + i;
  uint index2 = getIdx(groupId, groupIdy, j, k, blockDim, width);

  acc += dct8x8[index1] * input[index2];
  /* } */
}

```

**Fig. 10** A kernel with the inner loop horizontally parallelized. Here the work-item loop surrounds the inner-loop body, yielding a nicely parallelized region

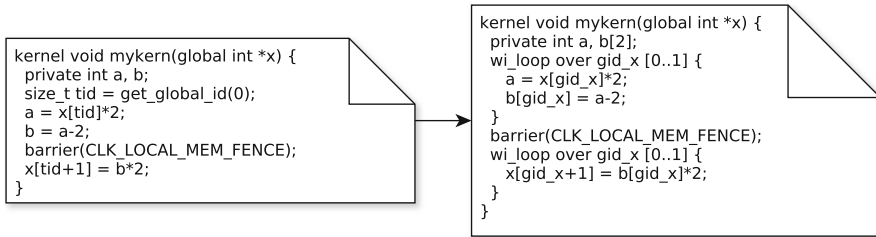
constant or a kernel argument. The uniformity analysis is used to prove that the loop exit condition nor the predicates in the path leading to the loop entry do not depend on the work-item id. That is, the work-item execution does not *diverge* in such a way that the implicit barrier insertion would be illegal. Only then the implicit loop barrier is inserted to enforce the horizontal inner loop parallelization.

#### 4.7 Handling of Kernel Variables

Variables of two different scope can be defined in OpenCL C kernel functions: The per work-item *private* variables and the *local* variables which are shared among all the work-items in the same work-group. While the *private* variables are always allocated in the OpenCL kernel function definition, there are two ways to allocate *local* variables in OpenCL kernels: From the host side through the *clSetKernelArg* API (a local buffer argument in the kernel function), and from the kernel side through “automatic local variables” (variables prefixed in the OpenCL C description with the *local* address space qualifier). Both of these cases are handled similarly by pocl by converting the latter case of automatic locals to an additional work-group function argument with a fixed allocation size. The additional work-group function argument for automatic locals is visible in the example kernel of Fig. 3. A third function argument has been added for storing the automatic float array of size four.

What should be noted is that *local* data is actually thread-local data from the point of view of the implementation when multiple work-groups are executed in parallel in multiple device threads sharing the same physical address space where the local data is stored. In order to ensure thread safety, e.g. the pthread device driver of pocl handles all local data by allocating the required local buffers in the “kernel launcher thread” which calls the work-group function. The same local space is reused across the possible multiple work-groups executing in the same device thread.

Private variables, however, need additional processing during the work-group function generation. As the original kernel function describes the functionality of a single work-item, the private variables in the produced multi-WI work-group function need to be replicated for all the work-items. In another point of view, if one considers each work-item to be an independent thread of execution, each of the threads must have their own separate private context that needs to be used during the execution. The straightforward way to produce such context space for the work-items is to create a *context*



**Fig. 11** Two cases of private variable lifespans: variable  $a$  is a temporary variable used only in one parallel region, while  $b$  spans across two parallel regions. The work-group function generation result is presented in pseudo code for clarity; in reality the processing is done on the LLVM internal representation and the actual variables seen by the kernel compiler might not match the ones in the input kernels due to earlier optimizations

*data array* for each original private variable. In this array, an element stores the private variable for a single work-item. Thus, as many elements as there are work-items in the work-group are needed.

Private variables have different life times that affect the need to store them in a context data array. Some of the private variables are used only within one parallel region while some span multiple regions. In case the lifetime does not span multiple parallel regions, there is no need to create a context array for it as the variable is used only during the execution of the work-item loop iteration. Such variables can be sometimes allocated to registers for their whole lifetime instead of storing them to memory. Figure 11 presents the two cases in a simple kernel which has two parallel regions due to the barrier in the middle. Variable  $a$  is used only in the first parallel region, thus, it can stay as a scalar within the produced work-item loop. In contrast,  $b$  is used also in the latter parallel region and has to be stored in a context array. In order to exploit the varying variable lifespans, each private variable is examined and if it is used on at least one parallel region different from that in which it is defined, a context array is created. Then, all uses of the variable are replaced by uses of an element of the newly created array. This analysis is straightforward in the SSA format; each variable assignment defines a new virtual variable of which uses can be found quickly.

Additional optimization the kernel compiler performs on the private variables of the work-group functions is the merging of uniform variables. The idea is similar to the *Loop-Invariant Code Motion (LICM)* [8]: sometimes the work-items in the work-item loop use variables that are invariant, i.e., the value does not change per work-item. In such cases, context data space can be saved by merging the variables to a single scalar variable that is shared across the work-items. If this is left to a later LICM optimization on the work-item loop, it might not succeed due to the need to analyze the accesses to the context array locations to prove the values are the same.

The kernel compiler uses the same uniformity analysis as was described in Sect. 4.6 to detect and merge such variables. In some cases this optimization is counter-productive in case it leads to the need to broadcast values across the lanes of SIMD-based machines, which might be expensive. In that case it can be more efficient to also replicate the uniform values just to avoid the communication costs. Taking advantage of this machine-specific property is left for future work.

## 5 Vectorized Mathematical Library Functions

OpenCL extends the usual mathematical elemental library functions found in C (e.g. `sin`, `cos`, `sqrt`) to accept vector arguments as well. To achieve good performance for computationally bound kernels, efficient, vectorized implementations for these are needed. We designed *Vecmathlib* [44] as a pocl sub-system to address this need. *Vecmathlib* provides efficient, accurate, tunable, and most importantly vectorized mathematical library functions. It seeks to design new algorithms for calculating elemental functions that execute efficiently when interspersed with other application code. This is in contrast to many other libraries, such as e.g. IBM's ESSL or Intel's VML, which are designed to be called with arrays of many (thousands) of elements at once.

*Vecmathlib* is implemented in C++, and intended to be called on SIMD vectors, e.g. those provided by SSE or AVX instruction sets, or available on ARM, Power7, and Blue Gene architectures. The same algorithms also work efficiently on accelerators such as GPUs. Even for scalar code, *Vecmathlib*'s algorithms are efficient on standard CPUs.

*Vecmathlib* consists of several components:

- Type traits, defining properties of the available floating-point types (such as half, float, double) and their integer equivalents (short, int, long), extending `std::numeric_limits`;
- Templates for SIMD vector types over these floating-point types, called `realvec<typename T, int D>`;
- Generic algorithms implementing mathematical functions; these algorithms act on SIMD vectors to ensure they are efficiently vectorized;
- Particular vector type definitions depending on the system architecture, providing e.g. `realvec<double, 2>` if Intel's SSE2 instructions are available. These definitions use efficient intrinsics (aka machine instructions) if available, or else fall back to a generic algorithm.

Thus *Vecmathlib* directly provides efficient vector types for those vector sizes that are supported by the hardware. Other vector sizes are then implemented based on these, so that e.g. `realvec<float, 2>` may be implemented via extension to `realvec<float, 4>` (with two unused vector elements), or `realvec<float, 8>` operations may be split into two `realvec<float, 4>` if necessary. This happens transparently, so that OpenCL's types `float2` or `float8` have their expected properties.

### 5.1 Implementation

Low-level mathematical functions such as `fabs`, `isnan`, or `signbit` are implemented via bit manipulation. These algorithms currently assume that floating point numbers use the IEEE layout [19,26], which happens to be the case on all modern floating-point architectures. For example, `fabs` is implemented by setting the sign bit to 0.

Mathematical functions where the inverse can be calculated efficiently, such as reciprocal or square root (where the inverses can be determined via a simple multiplication), are implemented via calculating an initial guess followed by an iterative

procedure. For example,  $\text{sqrt}(x)$  is implemented by first dividing the exponent by two via an integer shift operation, and then employing Newton's root finding method [42] via iterating  $r_{n+1} := (r_n + x/r_n)/2$  where  $r_n$  is the current approximation. This algorithm doubles the number of accurate digits with every iteration.

Most mathematical functions, however, are calculated via a range reduction followed by a polynomial expansion. For example,  $\sin(x)$  is calculated by first reducing the argument  $x$  to the range  $[0; 2\pi)$  via the sine function's periodicity, then reducing the range further to  $[0; \pi/2]$  via the sine function's symmetries, and finally expanding  $\sin(x)$  into Chebyshev polynomials [42] that minimize the maximum error in this range [38].

## 5.2 Vectorizing Scalar Code

Instead of implementing *vectorized* mathematical functions (that take vector arguments), it would be advantageous to implement *vectorizable* functions (that take scalar arguments), and which would then automatically be vectorized by the compiler. For example, the SLEEF library [45,46] takes this approach. This would certainly simplify the implementation of Vecmathlib itself. However, this is unfortunately not possible for the following reason: the high-level algorithms depend on low-level functions such as e.g. fabs, floor, or signbit. Whether these low-level functions are provided efficiently by vector hardware, or whether they need to be calculated via bit manipulation, is architecture dependent. We assume that LLVM's vectorizer will in the future be able to vectorize such calls. The logic required for this is exactly the logic already found in Vecmathlib, so one obvious way to implement this functionality in LLVM is via utilizing Vecmathlib.

## 6 Performance Evaluation

For evaluating the current performance of the proposed approach implemented in pocl, we used the suite of example applications available in the *AMD Accelerated Parallel Processing Software Development Kit* [7]. The example applications in the AMD APP SDK suite allow timing the execution and to iterate the benchmark multiple times. Multiple execution iterations are used to reduce cache effects to numbers and to allow the kernel compilers to amortize the kernel compilation time across kernel executions.

The benchmark suite was executed on various platforms supported by pocl. The same unmodified benchmark suite was also executed using the best found vendor implementation of OpenCL for the platform at hand for giving an idea where the performance is at in comparison to the most commonly used implementations. It should be noted that this version of the benchmark has been optimized for previous generation AMD GPUs with VLIW lanes. For example, many of the cases use explicit vector code which has to be scalarized by the pocl kernel compiler for more efficient horizontal work-group vectorization.

The processors in the tested platforms and their available parallel computation resource types are summarized in Table 1. Pocl framework exploits the parallel resources as follows: (a) thread-level parallelism (TLP); multiple work-groups in mul-

**Table 1** Different types of parallel computation resources exploited in the tested platforms

	TLP	ILP	DLP
Intel Corei7 [27]	4 cores, 2 threads each	8-issue out-of-order	AVX2 (8 float, 4 double)
ARM Cortex-A9 [12]	2 cores	Out-of-order	NEON
Power processor element	2 threads	2-issue in-order	AltiVec
TTA	n/a	Static multi-issue	n/a

The resources are categorized to the type of parallelism they serve: thread-level parallelism (TLP), instruction-level parallelism (ILP), and data-level parallelism (DLP)

multiple hardware threads or cores, (b) instruction-level parallelism (ILP); dynamic or static multi-issue cores enable concurrent execution of multiple operations from each parallel region (from the same work-item or from multiple work-items), and (c) data-level parallelism (DLP); SIMD instruction sets allow executing either intra-kernel vector instructions directly or lock-step executing matching operations from multiple work-items.

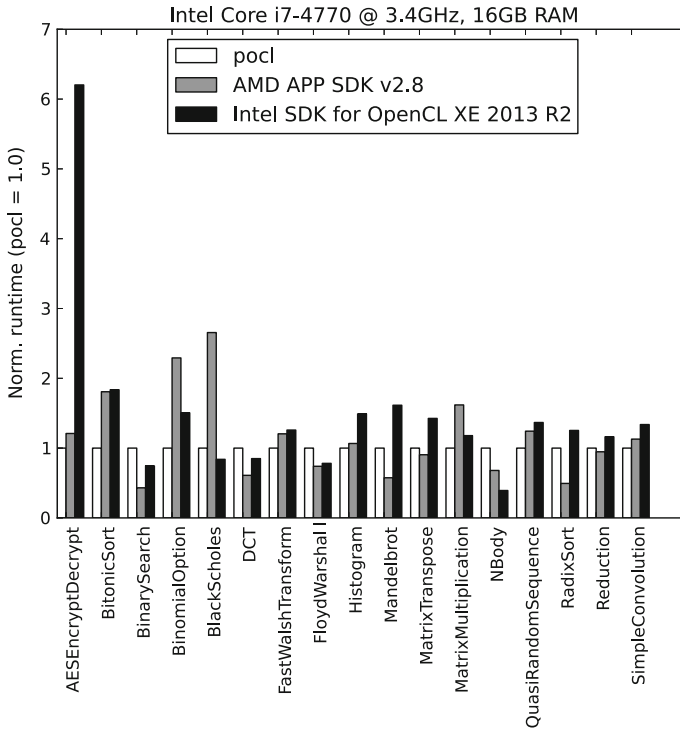
### 6.1 Intel x86-64

The first evaluated platform is the most popular instruction set architecture used in current personal computers and work stations, the Intel 64bit x86 architecture. For benchmarking this platform we used a workstation with an *Intel Core i7-4770* CPU clocked at 3.4 GHz. The workstation had 16 GB of RAM and ran the Ubuntu Linux 12.04 operating system. The kernel execution time performance results are given in Fig. 12. There were two proprietary OpenCL implementations on the platform we could compare against, one from AMD and another from Intel. This benchmark set indicates great performance can be achieved using pocl despite the fact that there are several performance opportunities that are under implementation. For several of the benchmark applications pocl already outperforms the available proprietary implementations. However, a few bad results stick out from the results: *BinarySearch* and *NBody*. We analyzed the cases and listed the additional optimizations that should help to reach the vendor implementation performance also for these cases. They are discussed in the Conclusions and Future Work section later.

### 6.2 ARM Cortex-A9

ARM CPUs are currently the standard choice for general purpose processing in mobile devices. We benchmarked the ARM platform using the PandaBoard with Ubuntu Linux 12.04 installed as the operating system. The PandaBoard has an *ARM Cortex-A9* [12] CPU which is an out-of-order multiscalar architecture with a NEON [11] SIMD unit. The CPU is clocked at 1 GHz, and the platform has 1 GB of RAM. On this platform we could not compare against a vendor supplied OpenCL implementation as ARM does not supply one (as of February, 2013) for their CPUs, but only for their Mali GPUs. Benchmarking results against FreeOCL [4] (albeit it is not a performance-oriented



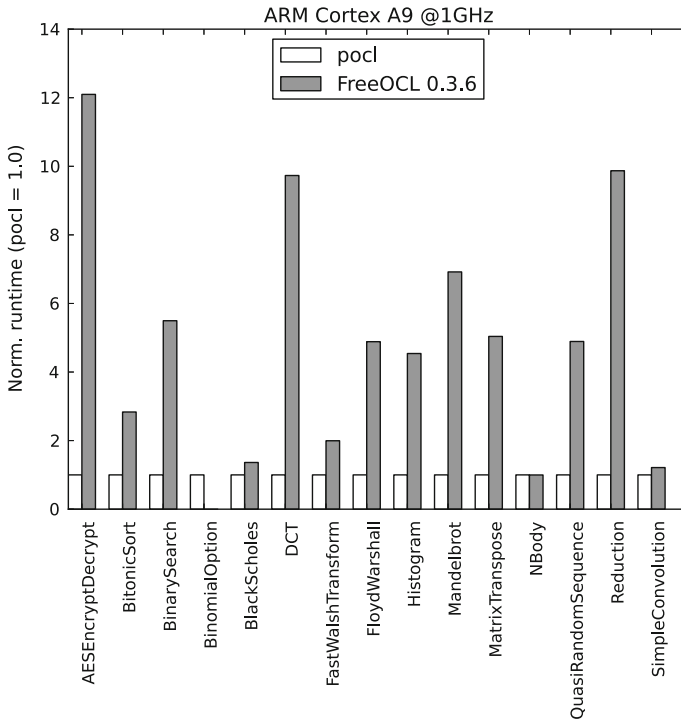


**Fig. 12** Benchmark execution times (smaller is better) with Intel Core i7, in a Linux environment. The benchmark runtime achieved with pocl is compared to the two available proprietary implementations for the platform

implementation) are shown in Fig. 13. The BinomialOption test case failed to work with FreeOCL.

### 6.3 STI Cell Broadband Engine/Power Processing Element

The Cell Broadband Engine [20] is a heterogeneous multiprocessor consisting of a PowerPC and 8 Synergistic Processing Units (SPU's). pocl can utilize the PowerPC via the *basic* and *threads* drivers. The *spu* driver in pocl can execute programs on the SPU processors. However, a majority of the test cases failed with compiler errors due to the immature state of the LLVM SPU backend. Also, as LLVM has removed the SPU backend since the 3.2 release, the benchmarks were not run on the SPU parts of the Cell. The PowerPC of the cell was benchmarked on a Sony Playstation 3, running the Debian *sid* operating system. The IBM OpenCL Development Kit v0.3 [24] was used as a benchmark reference on this platform. The reference benchmarks were run using the 'CPU'-device in both the OpenCL implementations, i.e. the SPUs were not used. The comparative results varied significantly (see Fig. 14) with pocl performing the best in the vast majority of the benchmarks.

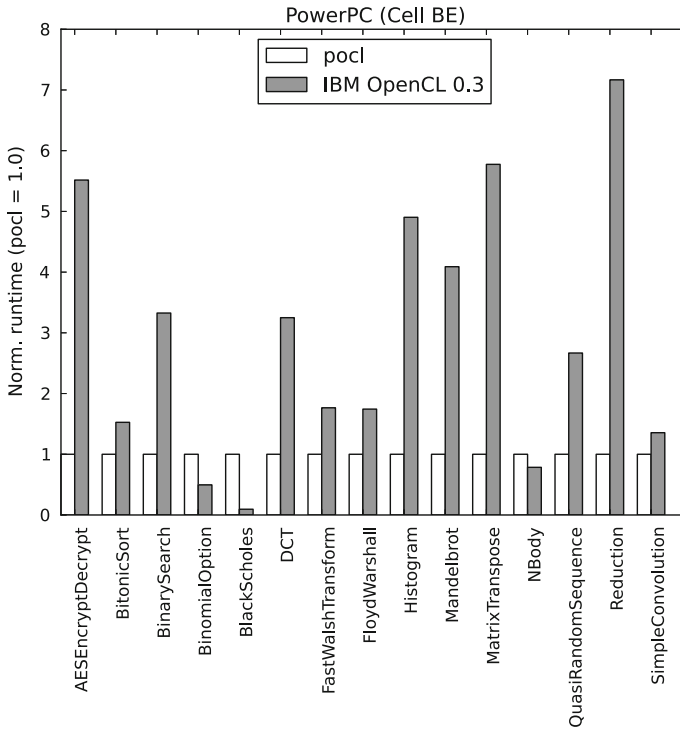


**Fig. 13** Benchmark execution times (*smaller is better*) with ARM Cortex-A9, 1GB RAM in Ubuntu Linux

#### 6.4 Static Multi-issue

An important feature of the pocl kernel compiler is its separation of parallelism exposing transformations (parallel region formation) and the actual parallelization of the known-parallel regions to the processor's resources. The platforms in the previous benchmarks have exploited the parallelism available in dynamic multi-issue CPUs, their SIMD extensions and multiple cores or hardware threads. Static multi-issue architectures are interesting especially in low power devices as they reduce the hardware logic needed to support parallel computation and they rely on the compiler to exploit the parallel function units in the machine [18]. In order to test how well the proposed kernel compilation techniques can exploit the parallelism in VLIW-style machines, we designed a *Transport Triggered Architecture (TTA)* processor with multiple parallel function units. For this, the publicly available processor design toolset *TCE (TTA-Based Co-design Environment)* [6, 17] was used.

*Transport Triggered Architecture (TTA)* is a VLIW architecture with a programmer exposed interconnection network [15]. It exposes the instruction level parallelism statically like the traditional VLIWs but adds more instruction scheduling freedom due to the transport programming model. For this benchmark we used a pocl device layer implementation that accesses the instruction set simulator engine of TCE for modeling a TTA-based accelerator device. The simulator engine is instruction cycle



**Fig. 14** Benchmark execution times (*smaller is better*) with STI CellBE @ 3.2GHz, 256MB RAM running Debian sid. Both OpenCL implementations utilize the PowerPC processor only

**Table 2** Computational resources in the TTA datapath used in the ILP benchmark

Resource	#
Integer register files (1rd+1wr port, 32 regs each)	4
Boolean register files (1rd+1wr port, 16 regs each)	5
Integer ALUs	4
Float add+sub units	4
Float multiplier units	4
Load-store units (for global and local)	9

count accurate, thus allows measuring the scalability of scheduling the multi-WI work-group functions statically to function units. The processing resources in the designed TTA are listed in Table 2.

The test application used here was the unmodified DCT benchmark from the AMD SDK. This benchmark is a good example which benefits from the inner loop horizontal parallelization of the kernel compiler to improve the exploitable parallelism (see Sect. 4.6). The kernel has two loops without barriers and have an iteration count given as the kernel argument. Thus, without the horizontal parallelization transformation, the loops could not be unrolled and are executed for each work-item in a

**Table 3** Performance benchmark results, showing execution time in cycles (lower is better)

Type	Vector size	Impl. (cycles)	Overhead (cycles)	Exp (cycles)	Sin (cycles)	Sqrt (cycles)
Float	1	libm	2.6	38.3	47.5	13.2
		SSE2	2.3	12.9	12.4	12.1
	4	libm	27.5	433.6	474.3	92.0
		SSE2	9.3	52.4	41.6	21.8
Double	1	libm	2.3	23.9	33.2	17.5
		SSE2	2.3	23.1	21.6	18.2
	2	libm	6.2	92.2	127.1	51.8
		SSE2	4.6	52.5	41.8	21.9

This compares a naive, scalarizing implementation via libm to Vecmathlib for exp, sin, and sqrt. The column “overhead” shows the approximate overhead of the benchmarking harness. Note that scalarization by itself is expensive since it requires vector shuffle operations (see overhead column). Note also that, in many cases, Vecmathlib is more efficient than calling libm even in the scalar case. On this system, exp and sin are implemented via a generic algorithm, whereas sqrt is implemented via a machine instruction

**Table 4** Performance benchmark results, showing execution time in cycles (lower is better)

Type	Vector size	Impl. (cycles)	Overhead (cycles)	Exp (cycles)	Sin (cycles)	Sqrt (cycles)
Float	1	libm	0.3	30.1	18.4	6.9
	4	libm	1.4	485.6	302.6	114.1
		Altivec	1.3	13.4	33.9	8.7

The qualitative results are similar to Table 3. On this system, exp and sin are implemented via a generic algorithm, whereas sqrt profits from a special machine instruction

sequence with very limited instruction-level parallelism. The kernel execution time without the horizontal parallelization was 53.5 ms and 10.2 ms (scaled to 100 MHz) when the horizontal inner loop parallelization pass was used. Thus, the ILP increase when exploiting the kernel parallelization pass was roughly fivefold.

## 6.5 Performance of the Built-in Functions

We evaluated the speed of certain mathematical functions implemented using the Vecmathlib for various vector sizes on an Intel Core i7 (with SSE4.2 vector instructions) and on a PS3 (with Altivec vector instructions). We compared scalarizing the function calls and marshalling them to libm, which presumably provides an optimized scalar calculation, to Vecmathlib’s vectorized implementation. Results are presented in Tables 3 and 4. The benchmarks used the `-ffast-math` option, and each calculation was repeated 10,000,000 times in a loop to obtain more accurate measurements.

It is clearly evident that Vecmathlib’s implementation is in all cases at least as efficient as libm, even in the scalar case. For vector types, Vecmathlib is always significantly more efficient, since scalarizing (disassembling and later re-assembling) a vector is an expensive operation in itself. In particular for single precision, Vecmathlib

is significantly faster (for `exp` and `sin`) than `libm`; this is presumably because `libm`'s implementation uses the Intel `fexp` and `fsin` machine instructions which always uses double precision, whereas `Vecmathlib` evaluates these functions only for single precision. For the scalar `sqrt` function, there is almost no speed difference, because both `libm` and `Vecmathlib` employ the SSE2 `sqrtss` instruction.

## 7 Related Work

There has been previous work related the kernel compiler transformations. For example, *Whole Function Vectorization (WFV)* [30,31] is a set of vectorization techniques tailored for efficient vectorization of SPMD descriptions such as the OpenCL work-group functions with multiple work-items. Similar approach is used in the *Implicit Vectorization Module* of Intel's OpenCL SDK [43]. These solutions rely on a certain type of parallel computation resources during the kernel compilation such as vector instruction set extensions and perform the vectorization by expanding the scalar operations to their vector counterparts, whenever possible. This style of "monolithic approaches" are platform specific with limited support for performance portability. That is, when adding support to new devices with different parallel hardware, larger part of the kernel compiler has to be updated. The approach taken by `pocl` is to split the work-group vectorization to a generic step that identifies the parallel regions, converts the regions to data parallel loops, and retains the parallelism information to the later stages of compilation. The later stages are the same as in a standard vectorizing compilation. Therefore, when porting `pocl` to a new platform that supports LLVM, minimal effort is needed to get a working and efficient implementation.

Extracting parallelism from sequential programs, especially from loops that are not (known to be) parallel is a challenge that has received extensive attention in the past decades. As an example of one of the more recent works, the techniques proposed by Nicolau et al. enhance the thread level parallelism of loops with inter-iteration dependencies by intelligent placement of *post and wait* synchronization primitives [39, 40]. In the case of the compilation flow presented in this article, the key problem is not the extraction of parallelism from a serial program because the input kernels are parallel by default and explicitly synchronized by barriers. The complexity is in finding at compile time the parallel regions of multiple instances of the work-item descriptions, and this parallelism is typically mapped to finer grain resources such as vector lanes or function units. However, the work of Nicolau et al. could be used to enlarge the found parallel regions to make their execution more efficient in machines that execute work-items from a single work-group in separate threads or cores.

The earliest mentions we found of the idea of generating "work-group functions" that execute multiple work-items in parallel to improve the performance of SPMD optimized programs on non-SPMD hardware has been published previously in the context of CUDA [47]. The same idea is referred to as "work-item coalescing" for OpenCL in [36]. The MCUDA ideas can be applied directly to OpenCL kernels as the concept of SPMD descriptions with barrier synchronization is identical in both languages. These previous works present the key idea of identifying regions that are parallel and executing them for all work-items. The previous works are implemented

as source-to-source transformations which is great for portability, but lacks the performance portability benefits. The feature that impacts the *performance portability* aspect the most is the transfer of parallelism information. In case of source to source approaches, the information is lost as the parallel regions are converted to serial loops, ending up with the usual alias analysis complexity present in, e.g. C loops. The transferring of parallel loop data using the LLVM IR metadata enables pocl to maintain the information of the data parallel regions in work-group and benefit the later optimization stages. We also perform additional parallelism-improving optimizations such as inner-loop parallelization of kernels without barriers by selectively converting them to kernels with implicit barriers, effectively parallelizing the outer loop (work-item loop). Finally, a major drawback of the source-based approaches is the language-dependence. With the introduction of the SPIR standard [34], it is now possible to define OpenCL kernels using multiple alternative languages. Because SPIR uses LLVM IR, the proposed kernel parallelization techniques apply to kernels loaded from SPIR binaries as well.

There are also previous attempts to provide portable OpenCL implementations. One of the well known ones is Clover [3], which is an OpenCL implementation providing GPU computation support using open source drivers. Clover implements the work-group barriers using light weight threads (or “fibers”). A similar fiber-based approach is *Twin Peaks* [21, 22], which proposes using optimized `setjmp/longjmp` functions for implementation. The drawback with the fiber approach is that the light weight threads do not allow implicit static parallelization of multi-WI work-groups [2]. Therefore, the performance portability and “scaling” is limited with these solutions. After all, the main source for parallelism in OpenCL kernels is the ability to execute operations from multiple work-items in any order, also statically using fine grained parallel resources such as SIMD or VLIW instructions. This cannot be achieved when threads with independent control are spawned for work-items. There are also overheads in the fiber approach due to the context switches itself, but it is clear that the capability to horizontally parallelize work-groups has the main performance benefit in the proposed work.

FreeOCL [4] is an open source implementation of the OpenCL 1.2. The target of FreeOCL is stated as “*It aims to provide a debugging tool and a reliable platform which can run everywhere.*” FreeOCL relies on an external C++ compiler to provide a platform portable implementation, but again does not provide a kernel compiler with static parallelization of work-items to improve *performance portability*. Like several other implementations, it relies on the fiber approach for implementing multi-WI work-group execution.

The proposed approach attempts to improve the performance portability over a wide range of platforms; the pocl kernel compilation does not rely on any specific parallel computation resources (unlike WFV, which relies on vectorization). This is apparent in its separation of the compiler analysis that expose the parallel regions between work-group barriers from the generic parallelization passes (such as vectorization or VLIW scheduling). This style of modularized kernel compilation improves the performance portability of the OpenCL implementation thanks to the freedom to map the parallel operations in the best way possible to the resources of the device at hand.

The proposed solution uses static program analysis to avoid using threads with independent control flow for executing multiple work-item kernels with barriers, which allows improved performance portability compared to fiber-based approaches like Clover and Twin Peaks. For improving the platform portability aspect, the proposed solution uses only C language for the the host API implementation (instead of C++ as used in Clover) in order to allow porting the code to a wider range of embedded platforms without extensive compiler or runtime support.

## 8 Conclusions and Future Work

In this article, we described a modular performance portable OpenCL kernel compiler and a portable OpenCL implementation called *pocl*. The modular kernel compiler provides an efficient basis for kernel compilation on various devices with parallel resources of different granularity. The kernel compiler is constructed to separate the analysis that expose the parallelism from multi-WI work-groups and to more standard optimizations that perform the actual static parallelization of the parallel regions to different styles of fine-grained parallel computation hardware, such as SIMD, VLIW, or superscalar architectures. The data parallelism information of multiple work-item work-group functions is transferred using LLVM IR metadata for later compilation phases. The experiments on different processor architectures showed that *pocl* can be used to port OpenCL applications efficiently and it can exploit various kinds of parallelism available in the underlying hardware. The *pocl* framework can also be used as an experimentation platform for the popular OpenCL programming standard, and it provides an OpenCL implementation framework for engineers designing new parallel computing devices.

The *pocl* kernel compiler itself is fully functional and usually very efficient. It was shown that most of the benchmarked applications were faster or close to as fast as the best proprietary OpenCL implementation for the platform at hand.

At its current state, most of the performance improvements to the kernel compiler of *pocl* will be language generic in nature. They can be implemented to the LLVM infrastructure and as a result benefit also non-OpenCL programs.

For example, we plan to add selective scalarization of vector code inside loops. That is, in case the loop vectorization cannot be applied for some reason, the original vector code added by the programmer should be left intact to still allow exploiting some SIMD instructions. Same applies to the aggressive inlining of built-ins and other functions. The current way of inlining everything to the kernel function can be counter-productive due to the larger instruction cache footprint in case it does not improve the vectorization or other form of static parallelization of the work-items. This will be more the case in the future as larger and larger kernels are implemented using OpenCL. We plan to more intelligently choose when to inline and when not on work-item loop basis. A method similar to the one presented in [13] could be used. All of the worst-performing cases presented in Sect. 6 would benefit from these.

Another bottleneck we identified is the limited support for if-conversion [10] in the current LLVM version. The inability to predicate some otherwise statically parallelizable work-item loops is one of the biggest slowdowns in the worst performing

benchmark cases. Related to this, there are several OpenCL-specific optimizations we plan to experiment with. For example, improving the parallelization of kernels with diverging branches (parts executed only by a subset of the work-items) is one of the low-hanging fruits. There is some previous work available that is targeted towards enhanced load-balancing which could be adapted to improving the fine-grained parallelization on machines with limited support for predication as well [32].

**Acknowledgments** The work has been financially supported by the Academy of Finland (funding decision 253087), Finnish Funding Agency for Technology and Innovation (Project “Parallel Acceleration”, funding decision 40115/13), ARTEMIS joint undertaking under Grant Agreement No. 641439 (ALMARVI), by NSF awards 0905046, 0941653, and 1212401, as well as NSERC grant 2012-RGPIN-1505. In addition to the financial supporters, the authors would also like to thank the constructive comments and references pointed out by the reviewers.

## References

1. Clang: A C language frontend for LLVM. <http://clang.llvm.org/>. Online; Accessed 5 Feb 2014
2. Clover Git: Implementing barriers. <http://people.freedesktop.org/steckdenis/clover/barrier.html>. Online; Accessed 18 May 2013
3. Clover Git: OpenCL 1.1 software implementation. <http://people.freedesktop.org/steckdenis/clover/index.html>. Online; Accessed 18 May 2013
4. freeocl: Multi-platform implementation of OpenCL 1.2 targeting CPUs. <http://code.google.com/p/freeocl/>. Online; Accessed 18 May 2013
5. LLVM compiler infrastructure. <http://llvm.org/>. Online; Accessed 5 Feb 2014
6. TTA-based codesign environment (TCE). <http://tce.cs.tut.fi>. Online; Accessed 18 May 2013
7. Advanced Micro Devices Inc: Accelerated parallel processing (APP) software development kit (SDK) v2.8 (2012)
8. Aho, A.V., Sethi, R., Ullman, J.D.: Compilers: Principles, Techniques, and Tools. Addison-Wesley Longman Publishing Co. Inc., Reading (1986)
9. Allen, F.E.: Control flow analysis. *ACM SIGPLAN Not.* **5**(7), 1–19 (1970)
10. Allen, J., Kennedy, K., Porterfield, C., Warren, J.: Conversion of control dependence to data dependence. In: *Proceedings of ACM Symposium Principles of Programming Languages*, Austin, TX, pp. 177–189 (1983)
11. ARM Ltd.: The ARM NEON™ general-purpose SIMD engine (2012). <http://www.arm.com/products/processors/technologies/neon.php>
12. ARM Ltd.: The ARM Cortex™ A9 processor (2013). <http://www.arm.com/products/processors/cortex-a/cortex-a9.php>
13. Cammarota, R., Nicolau, A., Veidenbaum, A.V., Kejariwal, A., Donato, D., Madhugiri, M.: On the determination of inlining vectors for program optimization. In: *Proceedings of 22nd International Conference on Compiler Construction*, CC’13, pp. 164–183. Springer, Berlin (2013). doi:10.1007/978-3-642-37051-9\_9
14. Cocke, J.: Global common subexpression elimination. In: *Proceedings of Symposium Compiler Optimization*, pp. 20–24. Urbana-Champaign, IL (1970)
15. Corporaal, H.: *Microprocessor Architectures: From VLIW to TTA*. Wiley, Chichester (1997)
16. Cytron, R., Ferrante, J., Rosen, B.K., Wegman, M.N., Zadeck, F.K.: Efficiently computing static single assignment form and the control dependence graph. *ACM Trans. Program. Lang. Syst.* **13**(4), 451–490 (1991)
17. Esko, O., Jääskeläinen, P., Huerta, P., de La Lama, C.S., Takala, J., Martínez, J.I.: Customized exposed datapath soft-core design flow with compiler support. In: *International Conference on Field Programmable Logic and Applications*, pp. 217–222. Milan, Italy (2010)
18. Fisher, J.: Trace scheduling: a technique for global microcode compaction. *IEEE Trans. Comput.* **C-30**(7), 478–490 (1981)
19. Goldberg, D.: What every computer scientist should know about floating-point arithmetic. *ACM Comput. Surv.* **23**, 5–48 (1991)



20. Gschwind, M., Hofstee, H.P., Flachs, B., Hopkins, M., Watanabe, Y., Yamazaki, T.: Synergistic processing in Cell's multicore architecture. *IEEE Micro* **26**, 10–24 (2006)
21. Gummaraju, J., Morichetti, L., Houston, M., Sander, B., Gaster, B.R., Zheng, B.: Twin peaks: a software platform for heterogeneous computing on general-purpose and graphics processors. In: *Proceedings of International Conference on Parallel Architectures and Compilation Techniques*, pp. 205–216. Vienna, Austria (2010)
22. Gummaraju, J., Sander, B., Morichetti, L., Gaster, B., Howes, L.: Efficient implementation of GPGPU synchronization primitives on CPUs. In: *Proceedings of ACM International Conference on Computing Frontiers*, pp. 85–86. Bertinoro, Italy (2010)
23. Hecht, M.S., Ullman, J.D.: Flow graph reducibility. In: *Proceedings of Annual ACM Symposium on Theory of Computing*, pp. 238–250. Denver, CO (1972)
24. IBM: OpenCL(TM) development kit for Linux on Power, v0.3 (2011)
25. IEEE, Piscataway, NJ: IEEE standard for information technology—portable operation system interface (POSIX). Shell and utilities., 2004 edn. (2004). Std 1003.1
26. IEEE, Piscataway, NJ: Standard for floating-point arithmetic (2008). Std 754-2008
27. Intel Corp.: Desktop 4th Gen IntelCore™ Processor Family: Datasheet, Vol. 1 (2013). Doc. No. 328897-004
28. Jääskeläinen, P., Sánchez de La Lama, C., Huerta, P., Takala, J.: OpenCL-based design methodology for application-specific processors. *Trans. HiPEAC* **5** (2011). <http://www.hipeac.net/node/4310>
29. Janssen, J., Corporaal, H.: Making graphs reducible with controlled node splitting. *ACM Trans. Program. Lang. Syst.* **19**(6), 1031–1052 (1997)
30. Karenberg, R., Hack, S.: Whole-function vectorization. In: *Proceedings of Annual IEEE/ACM International Symposium Code Generation and Optimization*, pp. 141–150. Chamonix, France (2011)
31. Karenberg, R., Hack, S.: Improving performance of OpenCL on CPUs. In: *Proceedings of International Conference on Compiler Construction*, pp. 1–20. Tallinn, Estonia (2012)
32. Kejariwal, A., Nicolau, A., Saito, H., Tian, X., Girkar, M., Banerjee, U., Polychronopoulos, C.D.: A general approach for partitioning N-dimensional parallel nested loops with conditionals. In: *Proceedings of 18th Annual ACM Symposium on Parallelism in Algorithms and Architectures, SPAA '06*, pp. 49–58. ACM, New York, NY, USA (2006). doi:[10.1145/1148109.1148117](https://doi.org/10.1145/1148109.1148117)
33. Khronos Group, Beaverton, OR: OpenCL Specification, v1.2r19 edn. (2012)
34. Khronos Group: SPIR 1.2 Specification for OpenCL (2014)
35. Lattner, C., Adve, V.: LLVM: A compilation framework for lifelong program analysis and transformation. In: *Proceedings of International Symposium on Code Generation Optimization*, p. 75 (2004)
36. Lee, J., Kim, J., Seo, S., Kim, S., Park, J., Kim, H., Dao, T.T., Cho, Y., Seo, S.J., Lee, S.H., Cho, S.M., Song, H.J., Suh, S.B., Choi, J.D.: An OpenCL framework for heterogeneous multicores with local memory. In: *Proceedings of the 19th International Conference on Parallel Architectures and Compilation Techniques, PACT '10*, pp. 193–204. ACM, New York, NY, USA (2010). doi:[10.1145/1854273.1854301](https://doi.org/10.1145/1854273.1854301)
37. Maher, B.A., Smith, A., Burger, D., McKinley, K.S.: Merging head and tail duplication for convergent hyperblock formation. In: *Proceedings of Annual IEEE/ACM International Symposium on Microarchitecture*, pp. 65–76. Orlando, FL (2006)
38. Muller, J.M.: *Elementary Functions: Algorithms and Implementation*. Birkhäuser, London (2006)
39. Nicolau, A., Li, G., Kejariwal, A.: Techniques for efficient placement of synchronization primitives. In: *Proceedings of the 14th ACM SIGPLAN Symposium on Principles and Practice of Parallel Programming, PPOPP '09*, pp. 199–208. ACM, New York, NY, USA (2009). doi:[10.1145/1504176.1504207](https://doi.org/10.1145/1504176.1504207)
40. Nicolau, A., Li, G., Veidenbaum, A.V., Kejariwal, A.: Synchronization optimizations for efficient execution on multi-cores. In: *Proceedings of the 23rd International Conference on Supercomputing, ICS '09*, pp. 169–180. ACM, New York, NY, USA (2009). doi:[10.1145/1542275.1542303](https://doi.org/10.1145/1542275.1542303)
41. Nvidia Corp., Santa Clara, CA: NVIDIA CUDA Compute Unified Device Architecture: Programming Guide, v2.0 edn. (2008)
42. Press, W.H., Teukolsky, S.A., Vetterling, W.T., Flannery, B.P.: *Numerical Recipes 3rd Edition: The Art of Scientific Computing*. Cambridge University Press, Cambridge (2007)
43. Rotem, N.: Intel OpenCL SDK vectorizer. LLVM Developer's Meeting (2011)
44. Schnetter, E.: Vecmathlib. <http://bitbucket.org/eschnett/vecmathlib>. Online; Accessed 5 Feb 2014
45. Shibata, N.: Efficient evaluation methods of elementary functions suitable for SIMD computation. In: *Journal of Computer Science on Research and Development, Proceedings of the International Supercomputing Conference ISC10*, vol. 25, pp. 25–32 (2010). doi:[10.1007/s00450-010-0108-2](https://doi.org/10.1007/s00450-010-0108-2)

46. Shibata, N.: SLEEF (SIMD library for evaluating elementary functions). Web Site (2013). <http://shibatch.sourceforge.net/>
47. Stratton, J.A., Stone, S.S., Hwu, W.M.W.: MCUDA: an efficient implementation of CUDA kernels for multi-core CPUs. In: J.N. Amaral (ed.) Languages and Compilers for Parallel Computing, LNCS, vol. 5335, pp. 16–30. Springer, Berlin (2008). doi:[10.1007/978-3-540-89740-8\\_2](https://doi.org/10.1007/978-3-540-89740-8_2)